

Inductive Sensors

Inductive sensors for analog distance measurement

Balluff inductive distance sensors BAW provide an absolute voltage- or current signal that changes proportionally to the distance of a metallic target. Objects of varying shape and size made of ferrous or non-ferrous materials damp the sensor to different degrees. This provides a simple way of detecting positions, distances and material differences.



Inductive Sensors for Analog Distance Measurement

Contents

Cylinder Designs

Ø 6.5	698
M8×1	698
M12×1	699
M18×1	703
M30×1.5	706
M12×1 high-pressure resistant	708

Block Designs

10×30×6 mm (R03)	709
20×30×8 mm (R06)	710
14×38.5×17 mm (Z05)	711
80×80×40 mm	712
80×45×20 mm	713

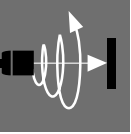

Basic information
and definitions
can be found
on **page 934**.



Inductive Sensors for Analog Distance Measurement

Features, output curve, evaluating programmed switching points

Features

- Distance-proportional analog output signal
- Contactless, absolute measuring principle
- Variety of form factors: cylindrical and cubical
- Measuring ranges from 0.5...50 mm
- High repeat accuracy
- Optimal linearity
- Low temperature drift
- Measuring speed up to 40 m/s
- LED for restricting the working range
- Insensitive to contamination

Output characteristics

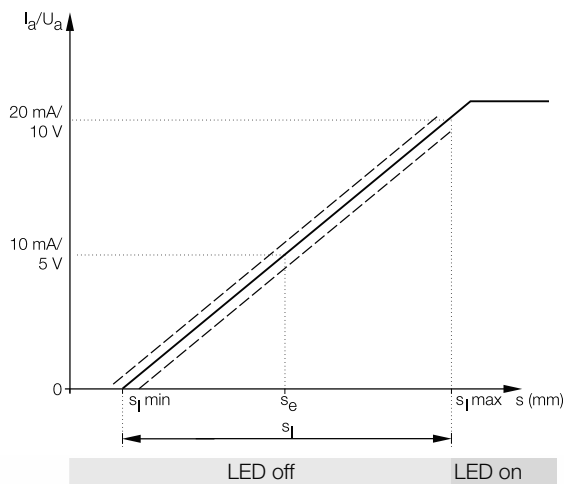

Evaluating programmed switching points (brake disk example)

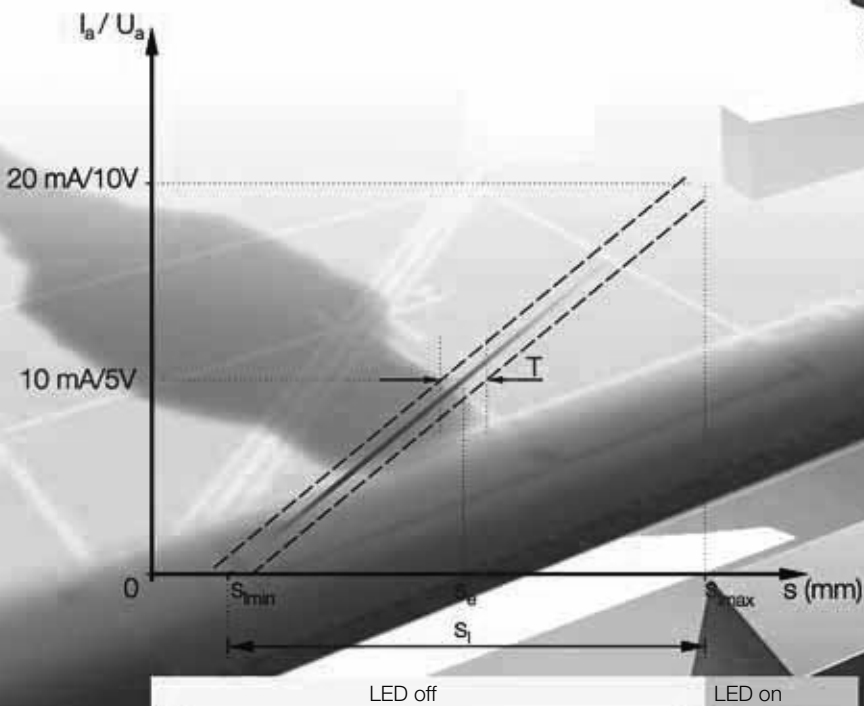
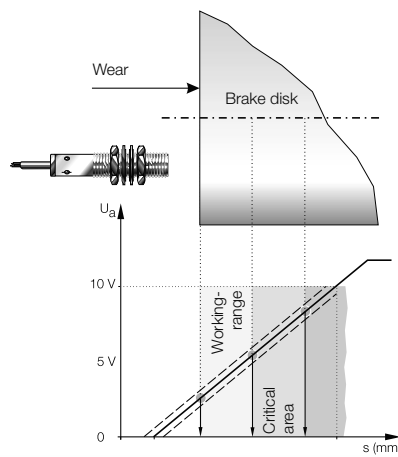

Inductive Sensors for Analog Distance Measurement

Sensors in use

Applications

- Some examples from a wide range of industrial applications:
- Distance sensing (even at high travel speeds)
 - Measurement of film and sheet thicknesses
 - Belt center measurement
 - Measurement of metal strip widths
 - Detection of surface waves
 - Counting tasks
 - Positioning
 - Position checking
 - Clamping distance monitoring
 - Selection of different sizes and materials

Axial approach

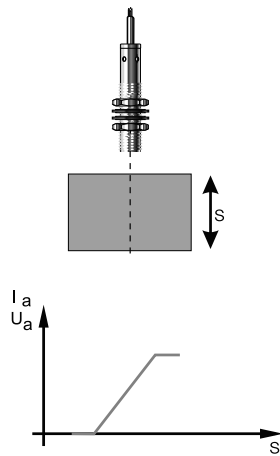

Distance changes in the sensor axis result in output signals proportional to distance.

Sensing a rotating object

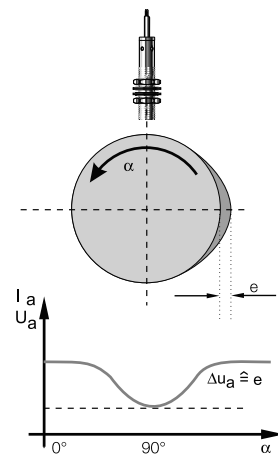

Eccentrics, cams or unbalanced motion result in a periodic change in the output signal.

Lateral approach

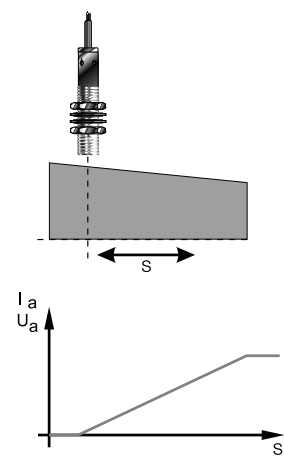

Detecting longer distances by sensing an inclined plane.

Sensing various materials

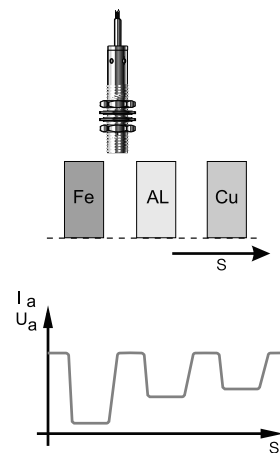

When the distance is kept constant, the output signal changes only when the object material is different.

Distance measurements at high object travel speeds

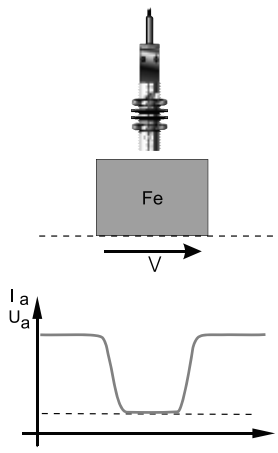

Even at high traverse speeds distances can be precisely measured.

Detecting installed seal rings

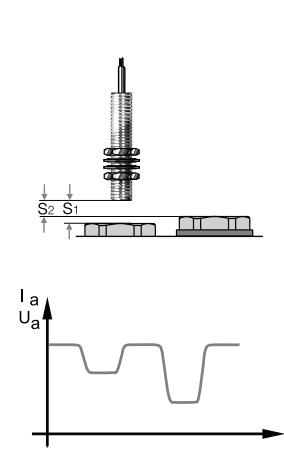

The seal ring effectively reduces the distance between the nut/screw and the sensor, thereby changing the output signal.

Tie rod length change on an injection molding machine

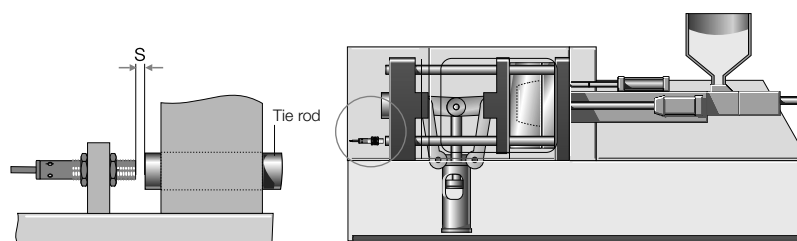

In injection molding machines, the clamping force of the tool is built up through a toggle joint and a hydraulic cylinder. The extension of the machine tie rods is thereby directly proportional to the clamping force, and can be easily determined using an inductive distance sensor.

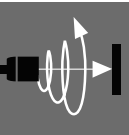

Inductive Sensors

Global DC 3-wire

DC 3-/4-wire

DC 2-wire

AC/DC 2-wire

AC 2-wire

Special Properties

Analog Distance Measurement

Cylinder Designs

Block Designs

Accessories

Inductive Sensors for Analog Distance Measurement

Cylinder designs, Ø 6.5 mm, M8x1



Temperature output

Model	Ø 6.5 mm	Ø 6.5 mm	M8x1
Installation type (observe instructions in the Basic Information chapter)	Flush	Flush	Flush
Output signal	Voltage, 0...10 V	Voltage, 0...10 V	Voltage, 0...10 V
Linear range s_L	0.5...2 mm	0.5...2 mm	0.5...1.5 mm
Ordering code	BAW000L	BAW000J	BAW000N
Part number	BAW G06EF-UAC20B-S49G	BAW G06EE-UAF20B-EP03-K	BAW M08EI-UAD15B-BP00,2-GS04
Supply voltage U_S	15...30 V DC	21.6...26.4 V DC	15...30 V DC
Rated insulation voltage U_I (protection class)	75 V DC	75 V DC	250 V AC (II)
Effective distance s_e	1.25 mm	1.25 mm	1 mm
Load resistance R_L min.	2 kΩ	5 kΩ	2 kΩ
Load resistance R_L max.			
Polarity reversal protected/transposition protected/short-circuit protected	Yes/Yes/Yes	No/No/No	Yes/Yes/Yes
Adjustment display (LED)	Yes	No	No
Ambient temperature T_a	+10...+60°C*	+10...+60°C*	-10...+70 °C
Repeat accuracy R_{BWN}	±40.0 μm	±10.0 μm	±8.0 μm
Non-linearity max.	±45 μm	±45 μm	±30 μm
Limit frequency (-3 dB)	1 kHz	1 kHz	1 kHz
Response time	0.5 ms	1 ms	0.5 ms
Temperature coefficient, typically in range from +10...+50 °C	-0.6 μm/K	-1 μm/K	-1 μm/K
Degree of protection as per IEC 60529	IP 67	IP 67	IP 67
Approvals	CE, cULus	CE	CE, cULus
Material	Housing: Stainless steel Sensing surface: PBT	Stainless steel PBT	Stainless steel PBT
Connection	M8 connector, 3-pin	3 m PUR cable, 4x0.14 mm ²	0.2 m PUR cable with M12 connector, 3-pin

* The function is also ensured over a range of -10...+70 °C

Wiring diagrams

Connector, voltage output

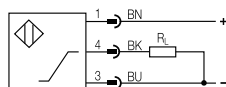

Cable, voltage output

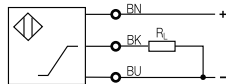

Connector, current output

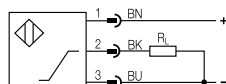

Cable, current output

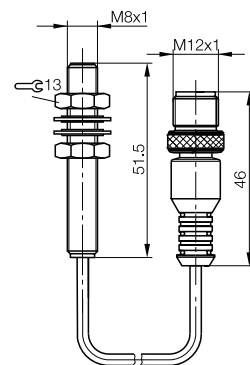
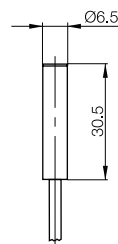
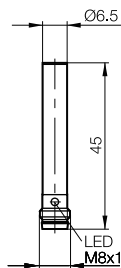
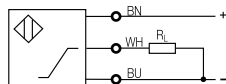

Temperature output

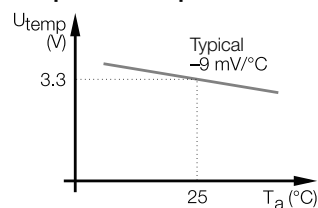

The temperature output (not short-circuit protected) provides a signal representing a precisely measured temperature change.

Inductive Sensors for Analog Distance Measurement

Cylinder designs, M8x1, M12x1

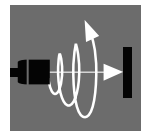

Inductive Sensors

Global DC 3-wire

DC 3-/4-wire

DC 2-wire

AC/DC 2-wire

AC 2-wire

Special Properties

Analog Distance Measurement

Cylinder Designs

Block Designs

Accessories

M8x1	M8x1	M8x1	M8x1	M12x1
Flush	Flush	Flush	Not flush	Flush
Voltage, 0...10 V	Voltage, 0...10 V	Voltage, 0...10 V	Voltage, 0...10 V	Current, 4...20 mA
0.5...1.5 mm	0.5...1.5 mm	0.5...1.5 mm	0.5...2.5 mm	0.5...2 mm
BAW003R	BAW000M	BAW000T	BAW000W	BAW001F
BAW M08EH-UAD15B-S04G	BAW M08EF-UAC15B-S49G	BAW M08EI-UAD15B-BP03	BAW M08EI-UAD25F-BP03	BAW M12MG2-ICC20B-BP00.2-GS04
15...30 V DC	15...30 V DC	15...30 V DC	15...30 V DC	10...30 V DC
250 V AC	250 V AC (□)	250 V AC (□)	250 V AC (□)	250 V AC (□)
1 mm	1 mm	1 mm	1.5 mm	1.25 mm
2 kΩ	2 kΩ	2 kΩ	2 kΩ	500 Ω
Yes/Yes/Yes	Yes/Yes/Yes	Yes/Yes/Yes	Yes/Yes/Yes	Yes/Yes/Yes
No	Yes	No	No	Yes
-10...+70 °C	-10...+70 °C	-10...+70 °C	-10...+60 °C*	-10...+70 °C
±40.0 μm	±40.0 μm	±8.0 μm	±10.0 μm	±5.0 μm
±30 μm	±30 μm	±30 μm	±60 μm	±45 μm
1 kHz	1 kHz	1 kHz	1 kHz	500 Hz
0.5 ms	0.5 ms	0.5 ms	1 ms	0.5 ms
0 μm/K	0 μm/K	-1 μm/K	-1.5 μm/K	-0.5 μm/K
IP 67	IP 67	IP 67	IP 67	IP 67
CE, cULus	CE, cULus	CE, cULus	CE, cULus	CE, cULus
Stainless steel	Stainless steel	Stainless steel	Stainless steel	Brass, coated
PBT	PBT	PBT	PBT	PBT
M12 connector, 3-pin	M8 connector, 3-pin	3 m PUR cable, 3x0.14 mm ²	3 m PUR cable, 3x0.14 mm ²	0.2 m PUR cable with M12 connector, 3-pin

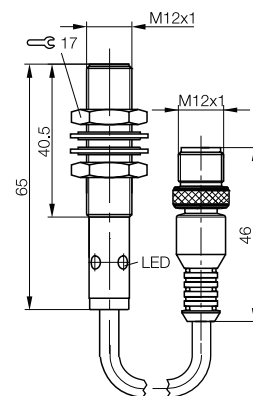
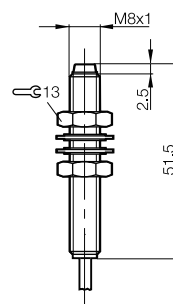
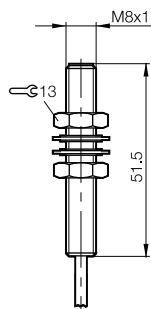
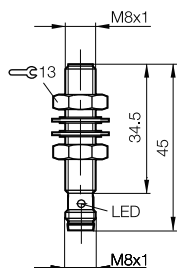
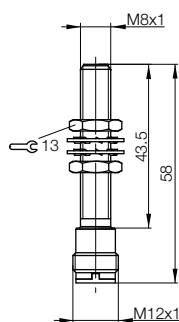

Inductive Sensors for Analog Distance Measurement

Cylinder designs, M12x1



Model	M12x1	M12x1	M12x1
Installation type (observe instructions in the Basic Information chapter)	Flush	Flush	Flush
Output signal	Current, 4...20 mA	Voltage, 0...10 V	Voltage, 0...10 V
Linear range s_l	0.5...2 mm	0.5...2 mm	0.5...2 mm
Ordering code	BAW001H	BAW001J	BAW001P
Part number	BAW M12MG2-ICC20B-BP03	BAW M12MG2-UAC20B-BP00,2-GS04	BAW M12MI-UAC20B-S04G
Supply voltage U_s	10...30 V DC	15...30 V DC	15...30 V DC
Rated insulation voltage U_i (protection class)	250 V AC (II)	250 V AC (II)	250 V AC (II)
Effective distance s_e	1.25 mm	1.25 mm	1.3 mm
Load resistance R_L min.		2 k Ω	2 k Ω
Load resistance R_L max.	500 Ω		
Polarity reversal protected/transposition protected/short-circuit protected	Yes/Yes/Yes	Yes/Yes/Yes	Yes/Yes/Yes
Adjustment display (LED)	Yes	Yes	Yes
Ambient temperature T_a	-10...+70 °C	-10...+70 °C	-10...+70 °C
Repeat accuracy R_{BWN}	± 6.0 μm	± 8.0 μm	± 8.0 μm
Non-linearity max.	± 45 μm	± 45 μm	± 45 μm
Limit frequency (-3 dB)	500 Hz	500 Hz	500 Hz
Response time	0.5 ms	0.5 ms	0.5 ms
Temperature coefficient, typically in range from +10...+50 °C	-0.5 $\mu\text{m}/\text{K}$	-1 $\mu\text{m}/\text{K}$	-0.5 $\mu\text{m}/\text{K}$
Degree of protection as per IEC 60529	IP 67	IP 67	IP 67
Approvals	CE, cULus	CE, cULus	CE, cULus
Material			
Housing	Brass, coated	Brass, coated	Brass, coated
Sensing surface	PBT	PBT	PBT
Connection	3 m PUR cable, 3x0.34 mm ²	0.2 m PUR cable with M12 connector, 3-pin	M12 connector, 3-pin

Wiring diagrams

Connector, voltage output

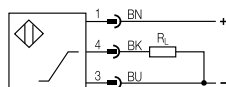

Cable, voltage output

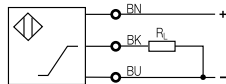

Connector, current output

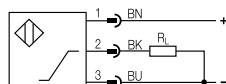

Cable, current output

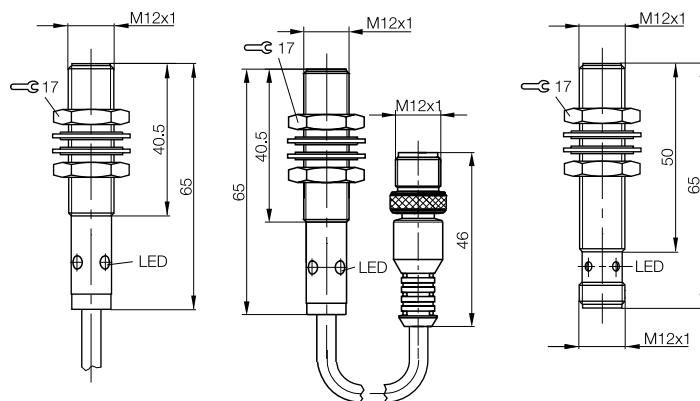
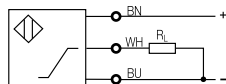

Inductive Sensors for Analog Distance Measurement

Cylinder designs, M12x1



Temperature output

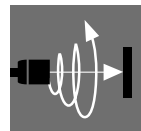

Inductive Sensors

Global DC 3-wire

DC 3-/4-wire

DC 2-wire

AC/DC 2-wire

AC 2-wire

Special Properties

Analog Distance Measurement

Cylinder Designs

Block Designs

Accessories

M12x1	M12x1	M12x1	M12x1	M12x1
Flush	Flush	Flush	Flush	Quasi-flush
Voltage, 0...10 V	Voltage, 0...10 V	Current, 0...20 mA	Current, 0...20 mA	Voltage, 0...10 V
0.5...2 mm	0.5...2 mm	0.5...2 mm	0.5...2 mm	1...5 mm
BAW0010	BAW001L	BAW0019	BAW001C	BAW0011
BAW M12ME-UAC20B-S04G	BAW M12MG2-UAC20B-BP03	BAW M12MG2-IAC20B-BP00,2-GS04	BAW M12MG2-IAC20B-BP03	BAW M12ME-UAD50B-BP01
15...30 V DC	15...30 V DC	10...30 V DC	10...30 V DC	15...30 V DC
250 V AC (⊠)	250 V AC (⊠)	250 V AC (⊠)	250 V AC (⊠)	75 V DC
1.25 mm	1.25 mm	1.25 mm	1.25 mm	3 mm
2 kΩ	2 kΩ	500 Ω	500 Ω	2 kΩ
Yes/Yes/Yes	Yes/Yes/Yes	Yes/Yes/Yes	Yes/Yes/Yes	Yes/Yes/Yes
Yes	Yes	Yes	Yes	No
-10...+70 °C	-10...+70 °C	-10...+70 °C	-10...+70 °C	0...+60 °C
±20.0 μm	±8.0 μm	±5.0 μm	±5.0 μm	±10.0 μm
±45 μm	±45 μm	±45 μm	±45 μm	±160 μm
500 Hz	500 Hz	500 Hz	500 Hz	1 kHz
0.5 ms	0.5 ms	0.5 ms	0.5 ms	2 ms
0 μm/K	-1 μm/K	-1 μm/K	-1 μm/K	-1.5 μm/K
IP 67	IP 67	IP 67	IP 67	IP 67
CE, cULus	CE, cULus	CE, cULus	CE, cULus	CE, cULus
Brass, coated	Brass, coated	Brass, coated	Brass, coated	Brass, coated
PBT	PBT	PBT	PBT	PA 12
M12 connector, 3-pin	3 m PUR cable, 3x0.34 mm ²	0.2 m PUR cable with M12 connector, 3-pin	3 m PUR cable, 3x0.34 mm ²	1 m PUR cable, 4x0.25 mm ²

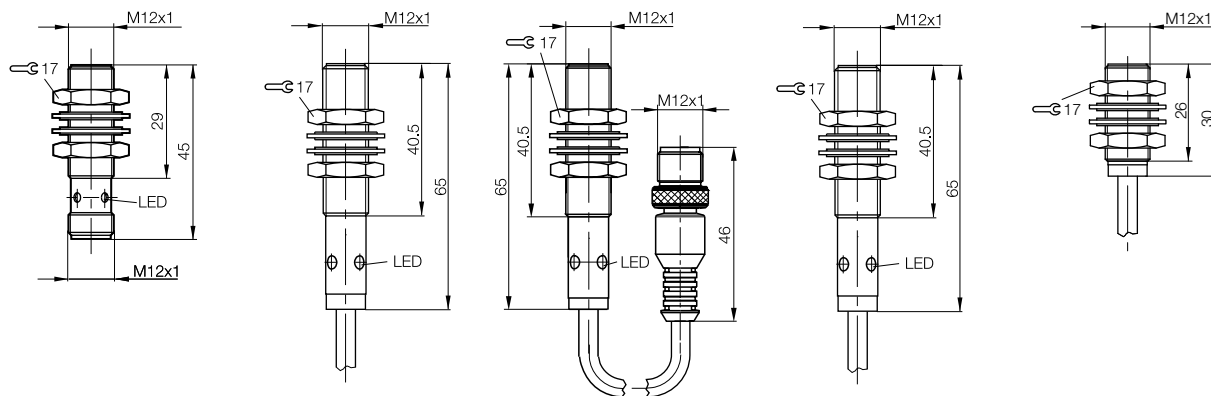

Temperature output

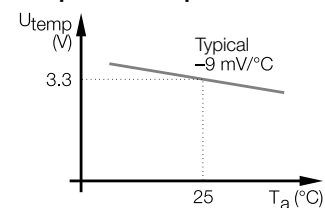

The temperature output (not short-circuit protected) provides a signal representing a precisely measured temperature change.

Inductive Sensors for Analog Distance Measurement

Cylinder designs, M12x1



Model	M12x1	M12x1	M12x1
Installation type (observe instructions in the Basic Information chapter)	Not flush	Not flush	Not flush
Output signal	Voltage, 0...10 V	Voltage, 0...10 V	Voltage, 0...10 V
Linear range s_l	1...4 mm	1...4 mm	1...4 mm
Ordering code	BAW0014	BAW000Z	BAW0017
Part number	BAW M12MF2-UAC40F-BP00,2-GS04	BAW M12MD-UAC40F-S04G	BAW M12MF2-UAC40F-BP03
Supply voltage U_s	15...30 V DC	15...30 V DC	15...30 V DC
Rated insulation voltage U_i (protection class)	250 V AC (II)	250 V AC (II)	250 V AC (II)
Effective distance s_e	2.5 mm		2.5 mm
Load resistance R_L min.	2 k Ω		2 k Ω
Load resistance R_L max.			
Polarity reversal protected/transposition protected/short-circuit protected	Yes/Yes/Yes	Yes/Yes/Yes	Yes/Yes/Yes
Adjustment display (LED)	Yes	Yes	Yes
Ambient temperature T_a	-10...+70 °C	-10...+70 °C	-10...+70 °C
Repeat accuracy R_{BWN}	$\pm 10.0 \mu\text{m}$	$\pm 10.0 \mu\text{m}$	$\pm 10.0 \mu\text{m}$
Non-linearity max.	$\pm 90 \mu\text{m}$	$\pm 90 \mu\text{m}$	$\pm 90 \mu\text{m}$
Limit frequency (-3 dB)	500 Hz	500 Hz	500 Hz
Response time	1 ms	1 ms	1 ms
Temperature coefficient, typically in range from +10...+50 °C	0 $\mu\text{m}/\text{K}$	-2 $\mu\text{m}/\text{K}$	0 $\mu\text{m}/\text{K}$
Degree of protection as per IEC 60529	IP 67	IP 67	IP 67
Approvals	CE, cULus	CE, cULus	CE, cULus
Material			
Housing	Brass, coated	Brass, coated	Brass, coated
Sensing surface	PBT	PBT	PBT
Connection	0.2 m PUR cable with M12 connector, 3-pin	M12 connector, 3-pin	3 m PUR cable, 3x0.34 mm ²

Wiring diagrams

Connector, voltage output

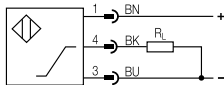

Cable, voltage output

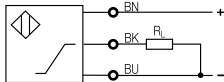

Connector, current output

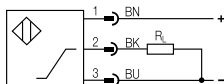

Cable, current output

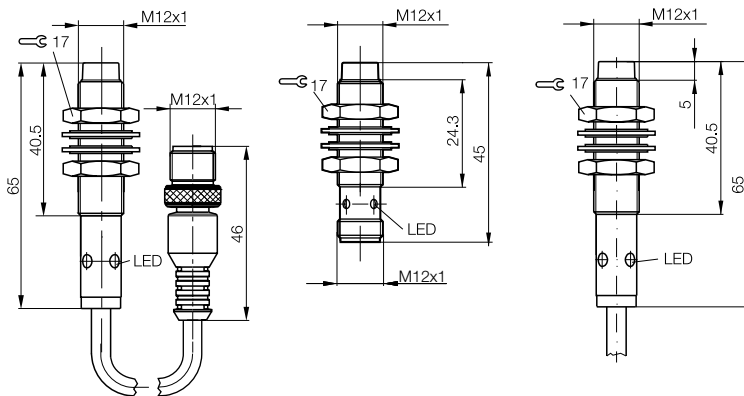
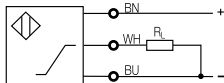

Inductive Sensors for Analog Distance Measurement

Cylinder designs, M12×1, M18×1



Temperature output

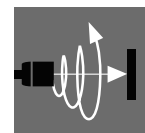

Inductive Sensors

Global DC 3-wire

DC 3-/4-wire

DC 2-wire

AC/DC 2-wire

AC 2-wire

Special Properties

Analog Distance Measurement

Cylinder Designs

Block Designs

Accessories

M12×1	M18×1	M18×1	M18×1	M18×1
Not flush	Flush	Flush	Flush	Flush
Current, 4...20 mA	Voltage, 0...10 V	Voltage, 0...10 V	Voltage, 0...10 V	Voltage, 0...10 V
1...4 mm	1...5 mm	1...5 mm	1...5 mm	1...5 mm
BAW003N	BAW001Z	BAW002K	BAW0026	BAW0025
BAW M12MH1-ICC40F-S04G	BAW M18ME-UAC50B-BP00,2-GS04	BAW M18MI-UAC50B-S04G	BAW M18ME-UAE50B-S04G-K	BAW M18ME-UAC50B-S04G
10...30 V DC	15...30 V DC	15...30 V DC	21.6...26.4 V DC	15...30 V DC
250 V AC (⊚)	75 V DC	250 V AC (⊚)	75 V DC	75 V DC
2.5 mm	2 kΩ	3 mm	3 mm	3 mm
500 Ω		2 kΩ	2 kΩ	2 kΩ
Yes/Yes/Yes	Yes/Yes/Yes	Yes/Yes/Yes	Yes/Yes/Yes	Yes/Yes/Yes
Yes	Yes	Yes	Yes	Yes
-10...+70 °C	-10...+70 °C	-10...+70 °C	-10...+70 °C	-10...+70 °C
±120 μm	±8.0 μm	±8.0 μm	±8.0 μm	±8.0 μm
500 Hz	±120 μm	±120 μm	±120 μm	±120 μm
0.5 ms	500 Hz	500 Hz	500 Hz	500 Hz
	1 ms	1 ms	1 ms	1 ms
	-1 μm/K	-2 μm/K	-1 μm/K	-2 μm/K
IP 67	IP 67	IP 67	IP 67	IP 67
CE, cULus	CE, cULus	CE, cULus	CE, cULus	CE, cULus
Brass, coated	Brass, coated	Brass, coated	Brass, coated	Brass, coated
PBT	PBT	PBT	PBT	PBT
M12 connector, 3-pin	0.2 m PUR cable with M12 connector, 3-pin	M12 connector, 3-pin	M12 connector, 4-pin	M12 connector, 3-pin

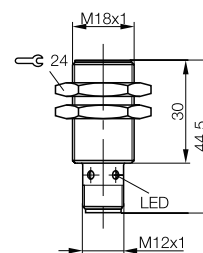
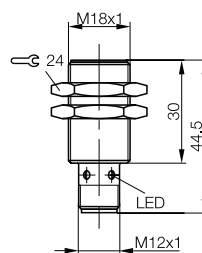
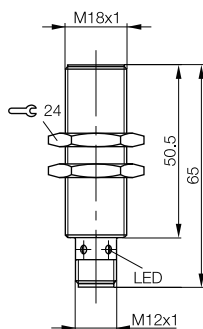
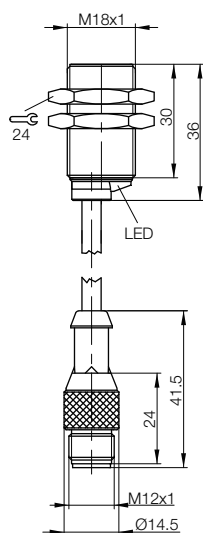
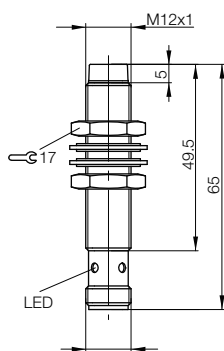

Temperature output

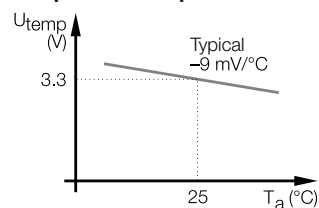

The temperature output (not short-circuit protected) provides a signal representing a precisely measured temperature change.

Inductive Sensors for Analog Distance Measurement

Cylinder designs, M18x1



With teach-in,
3 switching points



With Teach-in



Model	M18x1	M18x1	M18x1
Installation type (observe instructions in the Basic Information chapter)	Flush	Flush	Flush
Output signal	Voltage, 0...10 V	Voltage, 0...10 V	Voltage, 0...10 V
Linear range s_l	1...5 mm	1...5 mm	1...5 mm
Ordering code	BAW002M	BAW002U	BAW0022
Part number	BAW M18M12-UAC50B-BP05-002	BAW M18MM-UAZ50B-BP05-505	BAW M18ME-UAC50B-BP03
Supply voltage U_s	15...30 V DC	21.6...26.4 V DC	15...30 V DC
Rated insulation voltage U_i (protection class)	250 V AC (II)	250 V AC (II)	75 V DC
Effective distance s_e	3 mm	3 mm	3 mm
Load resistance R_L min.	2 k Ω	2 k Ω	2 k Ω
Load resistance R_L max.			
Polarity reversal protected/transposition protected/short-circuit protected	Yes/No/Yes	Yes/No/Yes	Yes/Yes/Yes
Adjustment display (LED)	Yes	No	Yes
Ambient temperature T_a	-10...+70 °C	-10...+70 °C	-10...+70 °C
Repeat accuracy R_{BWN}	$\pm 8.0 \mu\text{m}$	$\pm 8.0 \mu\text{m}$	$\pm 8.0 \mu\text{m}$
Non-linearity max.	$\pm 120 \mu\text{m}$	$\pm 120 \mu\text{m}$	$\pm 120 \mu\text{m}$
Limit frequency (-3 dB)	500 Hz	500 Hz	500 Hz
Response time	1 ms	1 ms	1 ms
Temperature coefficient, typically in range from +10...+50 °C	-1.5 $\mu\text{m}/\text{K}$	0 $\mu\text{m}/\text{K}$	-1 $\mu\text{m}/\text{K}$
Degree of protection as per IEC 60529	IP 67	IP 67	IP 67
Approvals	CE, cULus	CE, cULus	CE, cULus
Material			
Housing	Brass, coated	Brass, coated	Brass, coated
Sensing surface	PBT	PBT	PBT
Connection	5 m PUR cable, 7x0.25 mm ²	5 m PUR cable, 7x0.25 mm ²	3 m PUR cable, 3x0.34 mm ²

Wiring diagrams

Connector, voltage output

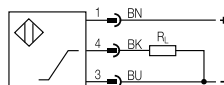

Cable, voltage output

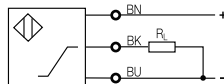

Connector, current output

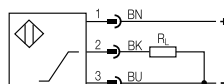

Cable, current output

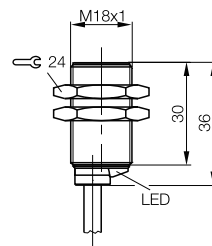
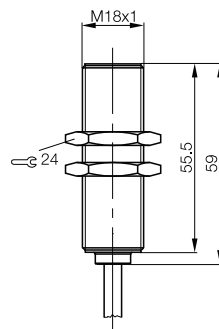
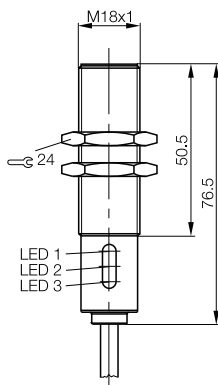
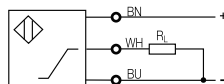

Inductive Sensors for Analog Distance Measurement

Cylinder designs, M18x1



IO-Link



M18x1	M18x1	M18x1	M18x1	M18x1
Flush	Flush	Flush	Flush	Flush
IO-Link, falling with rising proximity	Current, 0...20 mA	Current, 4...20 mA	Current, 4...20 mA	Current, 4...20 mA
1...5 mm	1...5 mm	1...5 mm	1...5 mm	1...5 mm
BAW002F	BAW002H	BAW002J	BAW001U	BAW001T
BAW M18MI-BLC50B-S04G	BAW M18MI-IAC50B-S04G	BAW M18MI-ICC50B-S04G	BAW M18ME-ICC50B-S04G	BAW M18ME-ICC50B-BP03
18...30 V DC	10...30 V DC	10...30 V DC	10...30 V DC	15...30 V DC
250 V AC (⊠)	250 V AC (⊠)	250 V AC (⊠)	75 V DC	75 V DC
3 mm	3 mm	3 mm	3 mm	3 mm
	500 Ω	500 Ω	500 Ω	500 Ω
Yes/Yes/Yes	Yes/Yes/Yes	Yes/Yes/Yes	Yes/Yes/Yes	Yes/Yes/Yes
Yes	Yes	Yes	Yes	Yes
-10...+70 °C	-10...+70 °C	-10...+70 °C	-10...+70 °C	-10...+70 °C
±10.0 μm	±8.0 μm	±8.0 μm	±8.0 μm	±8.0 μm
±120 μm	±120 μm	±120 μm	±120 μm	±120 μm
500 Hz	500 Hz	500 Hz	500 Hz	500 Hz
2 ms	1 ms	1 ms	1 ms	1 ms
-2 μm/K	-1 μm/K	-5 μm/K	-3 μm/K	-3 μm/K
IP 67	IP 67	IP 67	IP 67	IP 67
CE, cULus	CE, cULus	CE, cULus	CE, cULus	CE, cULus
Brass, coated	Brass, coated	Brass, coated	Brass, coated	Brass, coated
PBT	PBT	PBT	PBT	PBT
M12 connector, 3-pin	M12 connector, 3-pin	M12 connector, 3-pin	M12 connector, 3-pin	3 m PVC cable, 3×0.34 mm ²

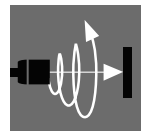

- Inductive Sensors
- Global DC 3-wire
- DC 3-/4-wire
- DC 2-wire
- AC/DC 2-wire
- AC 2-wire
- Special Properties
- Analog Distance Measurement
- Cylinder Designs
- Block Designs
- Accessories

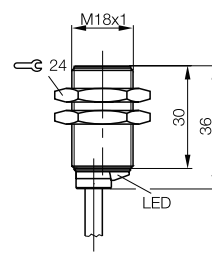
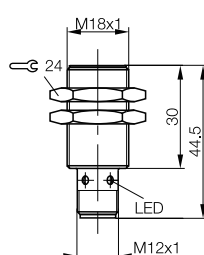
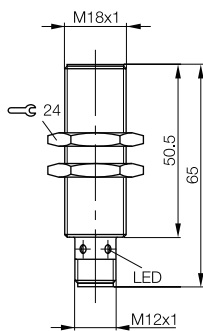
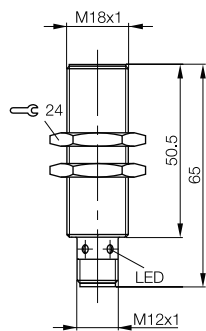
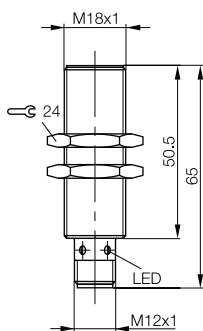

Inductive Sensors for Analog Distance Measurement

Cylinder designs, M18x1, M30x1.5



Temperature output

Model	M18x1	M18x1	M30x1.5
Installation type (observe instructions in the Basic Information chapter)	Not flush	Not flush	Flush
Output signal	Voltage, 0...10 V	Voltage, 0...10 V	Voltage, 0...10 V
Linear range s_L	2...8 mm	4...16 mm	2...10 mm
Ordering code	BAW002C	BAW0029	BAW002W
Part number	BAW M18MG-UAC80F-S04G	BAW M18MG-UAC16F-S04G-K	BAW M30ME-UAC10B-S04G
Supply voltage U_S	15...30 V DC	15...30 V DC	15...30 V DC
Rated insulation voltage U_i (protection class)	250 V AC (II)	250 V AC (II)	250 V AC (II)
Effective distance s_e	5 mm	10 mm	6 mm
Load resistance R_L min.	2 k Ω	2 k Ω	2 k Ω
Polarity reversal protected/transposition protected/short-circuit protected	Yes/Yes/Yes	Yes/Yes/Yes	Yes/Yes/Yes
Adjustment display (LED)	Yes	Yes	Yes
Ambient temperature T_a	-10...+70 °C	+10...+60°C*	-10...+70 °C
Repeat accuracy R_{BWN}	$\pm 12.0 \mu\text{m}$	$\pm 200.0 \mu\text{m}$	$\pm 10.0 \mu\text{m}$
Non-linearity max.	$\pm 180 \mu\text{m}$	$\pm 360 \mu\text{m}$	$\pm 240 \mu\text{m}$
Limit frequency (-3 dB)	500 Hz	500 Hz	500 Hz
Response time	1.5 ms	3 ms	1.5 ms
Temperature coefficient, typically in range from +10...+50 °C	-3 $\mu\text{m}/\text{K}$	8 $\mu\text{m}/\text{K}$	1.5 $\mu\text{m}/\text{K}$
Degree of protection as per IEC 60529	IP 67	IP 67	IP 67 per BWN Pr. 14
Approvals	CE, cULus	CE, cULus	CE, cULus
Material	Housing: Brass, coated Sensing surface: PBT	Brass, coated PBT	Brass, coated PBT
Connection	M12 connector, 3-pin	M12 connector, 3-pin	M12 connector, 3-pin

* The function is also ensured over a range of -10...+70 °C

Wiring diagram

Connector, voltage output

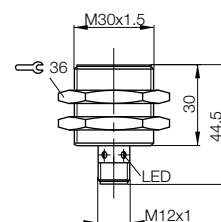
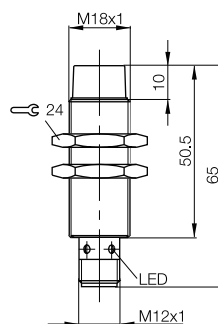
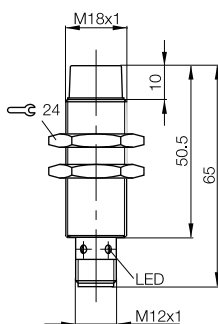
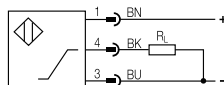

Temperature output

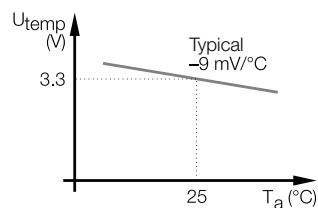

The temperature output (not short-circuit protected) provides a signal representing a precisely measured temperature change.

Inductive Sensors for Analog Distance Measurement

Cylinder designs, M30×1.5, PG36

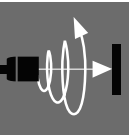

Inductive
Sensors

Global
DC 3-wire

DC 3-/4-wire

DC 2-wire

AC/DC 2-wire

AC 2-wire

Special
Properties

Analog
Distance
Measurement

**Cylinder
Designs**

Block Designs

Accessories

M30×1.5	PG36			
Not flush	Flush			
Voltage, 0...10 V	Voltage, 0...10 V			
3...15 mm	0...20 mm			
BAW002Y	BAW003M			
BAW M30ME-UAC15F-S04G	BAW MKZ-471.19-S4			
15...30 V DC	20...30 V DC			
250 V AC (□)	75 V DC			
9 mm	10 mm			
2 kΩ	10 kΩ			
Yes/Yes/Yes	Yes/Yes/Yes			
Yes	Yes			
-10...+70 °C	-10...+70 °C			
±12.0 μm	±5.0 μm			
±360 μm	±600 μm			
350 Hz	20 Hz			
3 ms				
1.5 μm/K	-1 μm/K			
IP 67	IP 67			
CE, cULus	CE			
Brass, coated	Brass, coated			
PBT	PBT			
M12 connector, 3-pin	M12 connector, 3-pin			

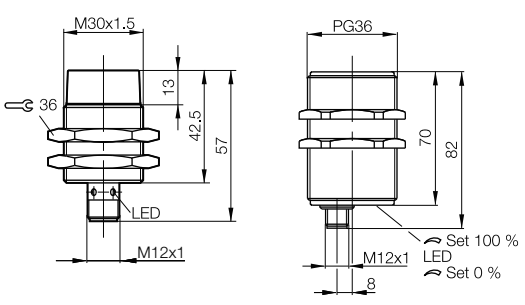

Inductive Sensors for Analog Distance Measurement

Cylinder design, high-pressure resistant M12×1

- Analog for control of valves or soft stop
- Measurements of valves and cylinders possible
- Ceramic on medium side – robust
- Oil pressure up to 500 bar

Application areas

- Control of valves
- Parked position of cranes
- Final position of installation supports
- Service measurements of valves
- Position monitoring in mobile hydraulic systems
- Control of agricultural technology



Model	M12×1
Installation type (observe instructions in the Basic Information chapter)	Flush
Output signal	Voltage, 0...10 V
Linear range s_l	0.5...2 mm
Ordering code	BAW0040
Part number	BAW Z08EO-UAD20B-S04G-H11
Supply voltage U_S	15...30 V DC
Rated insulation voltage U_i (protection class)	75 V DC
Effective distance s_e	1.25 mm
Load resistance R_L min.	2 k Ω
Polarity reversal protected/transposition protected/short-circuit protected	Yes/Yes/Yes
Adjustment display (LED)	No
Ambient temperature T_a	-25...+85 °C
Repeat accuracy R_{BWN}	$\pm 8.0 \mu\text{m}$
Non-linearity max.	$\pm 45 \mu\text{m}$
Limit frequency (-3 dB)	1 kHz
Response time	1 ms
Temperature coefficient, typically in range from +10...+50 °C	-1 $\mu\text{m/K}$
Degree of protection as per IEC 60529	IP 68
Approvals	CE, cULus
Material	Housing: Stainless steel Sensing surface: Ceramic
Connection	M12 connector, 3-pin

Wiring diagram

Connector, voltage output

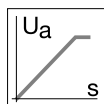
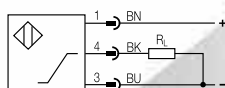

500 bar

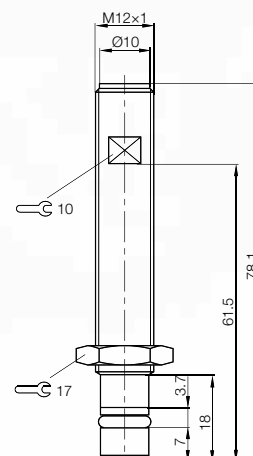

Inductive Sensors for Analog Distance Measurement

Block design, 10×30×6 mm

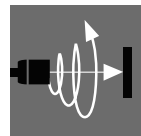

Inductive Sensors

Global DC 3-wire

DC 3-/4-wire

DC 2-wire

AC/DC 2-wire

AC 2-wire

Special Properties

Analog Distance Measurement

Cylinder Designs
Block Designs

Accessories

Model	10×30×6 mm R03	10×30×6 mm R03
Installation type (observe instructions in the Basic Information chapter)	Flush	Flush
Output signal	Voltage, 0...10 V	Voltage, 0...10 V
Linear range s_L	1...4 mm	1...4 mm
Ordering code	BAW0030	BAW0031
Part number	BAW R03KC-UAE40B-BP00,3-GS26	BAW R03KC-UAE40B-BP00,3-GS49
Supply voltage U_S	21.6...26.4 V DC	21.6...26.4 V DC
Rated insulation voltage U_i (protection class)	75 V DC	75 V DC
Effective distance s_e	2.5 mm	2.5 mm
Load resistance R_L min.	5 k Ω	5 k Ω
Polarity reversal protected/transposition protected/short-circuit protected	No/No/No	No/No/No
Adjustment display (LED)	Yes	Yes
Ambient temperature T_a	0...+70 °C	0...+70 °C
Repeat accuracy R_{BWN}	$\pm 35.0 \mu\text{m}$	$\pm 35.0 \mu\text{m}$
Non-linearity max.	$\pm 150 \mu\text{m}$	$\pm 150 \mu\text{m}$
Limit frequency (-3 dB)	1 kHz	1 kHz
Response time	0.5 ms	0.5 ms
Temperature coefficient, typically in range from +10...+50 °C	4.7 $\mu\text{m}/\text{K}$	4.7 $\mu\text{m}/\text{K}$
Degree of protection as per IEC 60529	IP 67	IP 67
Approvals	CE, cULus	CE, cULus
Material	Housing Sensing surface	Housing Sensing surface
	PA6-FG30 PA6-FG30	PA6-FG30 PA6-FG30
Connection	0.3 m PUR cable with M5 connector, 3-pin	0.3 m PUR cable with M8 connector, 3-pin

Installation note for BAW R03...

Material	Installation dimensions x
Steel	0 mm
Brass	5 mm
Aluminum	5 mm
Stainless steel	5 mm

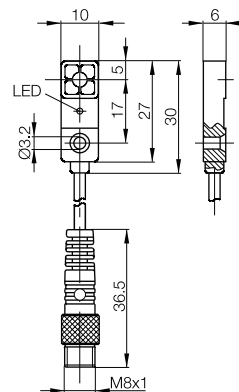
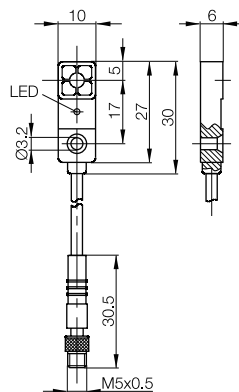
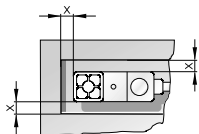

Wiring diagram

Connector, voltage output

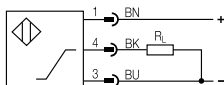

Inductive Sensors for Analog Distance Measurement

Block designs, 10×30×6 mm, 20×30×8 mm



Model	10×30×6 mm R03	20×30×8 mm R06	
Installation type (observe instructions in the Basic Information chapter)	Flush	Flush	
Output signal	Voltage, 0...10 V	Voltage, 0...10 V	
Linear range s_l	1...4 mm	0.5...2 mm	
Ordering code	BAW0032	BAW0034	
Part number	BAW R03KC-UAE40B-BP03	BAW R06AC-UAF20B-S49G	
Supply voltage U_s	21.6...26.4 V DC	21.6...26.4 V DC	
Rated insulation voltage U_i (protection class)	75 V DC	75 V DC	
Effective distance s_e	2.5 mm	1.3 mm	
Load resistance R_L min.	5 k Ω	5 k Ω	
Polarity reversal protected/transposition protected/short-circuit protected	No/No/No	No/No/No	
Adjustment display (LED)	Yes	No	
Ambient temperature T_a	0...+70 °C	-10...+70 °C	
Repeat accuracy R_{BWN}	$\pm 35.0 \mu\text{m}$	$\pm 12.0 \mu\text{m}$	
Non-linearity max.	$\pm 150 \mu\text{m}$	$\pm 45 \mu\text{m}$	
Limit frequency (-3 dB)	1 kHz	1 kHz	
Response time	0.5 ms	0.5 ms	
Temperature coefficient, typically in range from +10...+50 °C	5 $\mu\text{m}/\text{K}$	0.5 $\mu\text{m}/\text{K}$	
Degree of protection as per IEC 60529	IP 67	IP 67	
Approvals	CE, cULus	CE	
Material	Housing PA6-FG30	Anodized aluminum	
	Sensing surface PA6-FG30	PBT	
Connection	3 m PUR cable, 3×0.14 mm ²	M8 connector, 3-pin	

* The function is also ensured over a range of -10...+70 °C

Wiring diagrams

Connector, voltage output

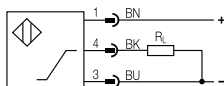

Cable, voltage output

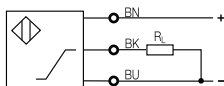

Connector, current output

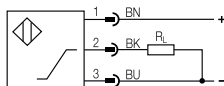

Cable, current output

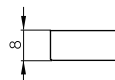
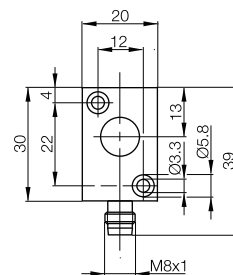
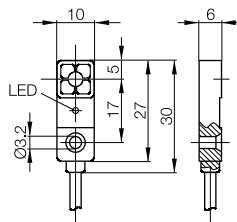
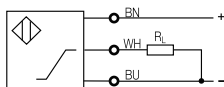

Inductive Sensors for Analog Distance Measurement

Block designs 20×30×8 mm, 14×38.5×17 mm



20×30×8 mm R06	14×38.5×17 mm Z01	14×38.5×17 mm Z01	14×38.5×17 mm Z05
Flush			
Voltage, 0...10 V	Voltage, 0...10 V	IO-Link, falling with rising proximity	IO-Link, falling with rising proximity
0.5...2 mm	1...5 mm	1...5 mm	1...5 mm
BAW0033	BAW003E	BAW003A	BAW003W
BAW R06AC-UAF20B-EP03	BAW Z01AC-UAD50B-DP03-K	BAW Z01AC-BLD50B-DP03	BAW Z05AC-BLD50B-BP00,75-GS04
21.6...26.4 V DC	15...30 V DC	18...30 V DC	18...30 V DC
75 V DC	75 V DC	75 V DC	75 V DC
1.25 mm	3 mm	3 mm	3 mm
5 kΩ	2 kΩ		
No/No/No	Yes/No/Yes	Yes/Yes/Yes	Yes/Yes/Yes
No	No		
+10...+60°C*	-10...+60 °C	-10...+60 °C	-10...+60 °C
±12.0 μm	±10.0 μm	±10.0 μm	±10.0 μm
±45 μm	±120 μm	±150 μm	±150 μm
1 kHz	1 kHz	200 Hz	200 Hz
0.5 ms	1 ms	5 ms	5 ms
0.5 μm/K	-3 μm/K	-3 μm/K	-3 μm/K
IP 67	IP 67	IP 67	IP 67
CE	CE, cULus	CE, cULus	CE, cULus
Anodized aluminum	Anodized aluminum	Anodized aluminum	Anodized aluminum
PBT	PA 12	LCP	LCP
3 m PUR cable, 3×0.14 mm ²	3 m PUR cable, 4×0.14 mm ²	3 m PUR cable, 4×0.14 mm ²	0.75 m PUR cable with M12 connector, 3-pin

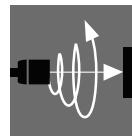

Inductive Sensors

Global DC 3-wire

DC 3-/4-wire

DC 2-wire

AC/DC 2-wire

AC 2-wire

Special Properties

Analog Distance Measurement

Cylinder Designs

Block Designs

Accessories

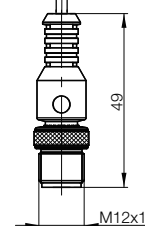
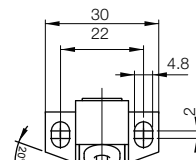
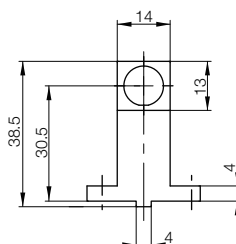
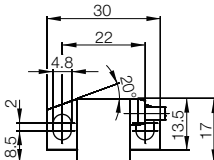
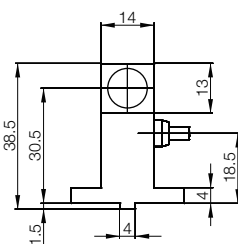
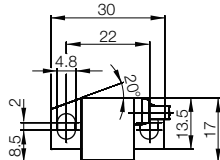
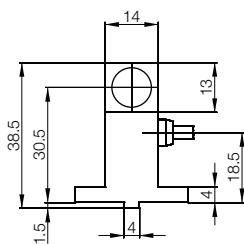
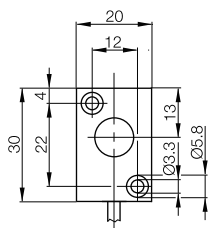

Temperature output

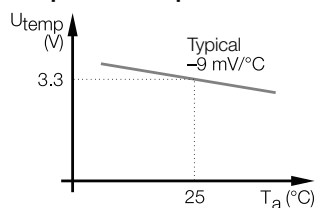

The temperature output (not short-circuit protected) provides a signal representing a precisely measured temperature change.

Temperature output

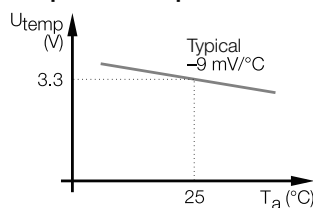

The temperature output (not short-circuit protected) provides a signal representing a precisely measured temperature change.

Inductive Sensors for Analog Distance Measurement

Block designs, 80×80×40 mm



Model	80×80×40 mm Maxisensor
Installation type (observe instructions in the Basic Information chapter)	Not flush
Output signal	Voltage, 0...10 V
Linear range s_l	0...50 mm
Ordering code	BAW003K
Part number	BAW MKK-050.19-S4
Supply voltage U_s	20...30 V DC
Rated insulation voltage U_i (protection class)	75 V DC
Effective distance s_e	25 mm
Load resistance R_L min.	10 k Ω
Polarity reversal protected/transposition protected/short-circuit protected	Yes/Yes/Yes
Adjustment display (LED)	No
Ambient temperature T_a	-10...+70 °C
Repeat accuracy R_{BWN}	$\pm 12.0 \mu\text{m}$
Non-linearity max.	$\pm 1500 \mu\text{m}$
Limit frequency (-3 dB)	15 Hz
Temperature coefficient, typically in range from +10...+50 °C	15 $\mu\text{m/K}$
Degree of protection as per IEC 60529	IP 67
Approvals	CE
Material	Housing Sensing surface
	PBT PBT
Connection	M12 connector, 3-pin

Wiring diagram

Connector, voltage output

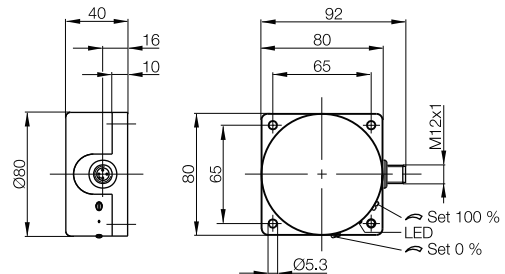
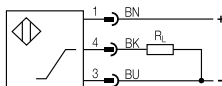

Inductive Sensors for Analog Distance Measurement

Block designs, 80×45×20 mm



Model	80×45×20 mm analog ring sensor
Installation type (observe instructions in the Basic Information chapter)	
Output signal	Voltage, 0...10 V
Linear range s_L	0...60 mm
Ordering code	BAW003L
Part number	BAW MKV-020.19-S4
Supply voltage U_S	15...30 V DC
Rated insulation voltage U_I (protection class)	75 V DC
Effective distance s_e	30 mm
Load resistance $R_{L \min}$	2 k Ω
Polarity reversal protected/transposition protected/short-circuit protected	Yes/No/Yes
Adjustment display (LED)	Yes
Ambient temperature T_a	-10...+70 °C
Repeat accuracy R_{BWN}	$\pm 200 \mu\text{m}$
Non-linearity max.	$\pm 1500 \mu\text{m}$
Response time	1 ms
Temperature coefficient, typically in range from +10...+50 °C	100 $\mu\text{m}/\text{K}$
Degree of protection as per IEC 60529	IP 67
Approvals	CE
Material	Housing: PBT Sensing surface: PBT
Connection	M12 connector, 3-pin

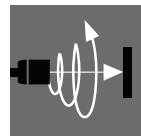

Inductive Sensors

Global DC 3-wire

DC 3-/4-wire

DC 2-wire

AC/DC 2-wire

AC 2-wire

Special Properties

Analog Distance Measurement

Cylinder Designs

Block Designs

Accessories

Wiring diagram

Connector, voltage output

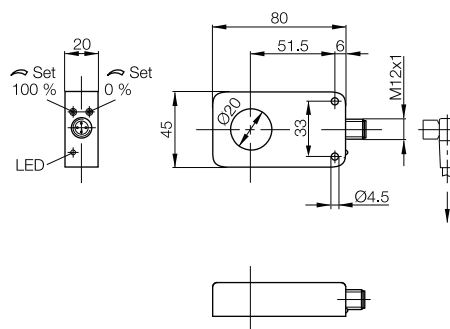
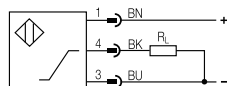

Compact analog- ring sensor with 20 mm opening. Measured value changes are produced by different metallic objects or insertion depths.

Applications include thickness measurement of various screws, rods or wires, and position measurement on machines by inserting conical objects into the sensor.

Testing cone for determining insertion depth (measuring range and linearization)

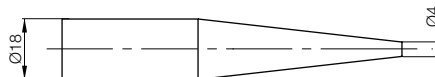

Installation conditions



No mutual interference for front-mounting of two sensors.

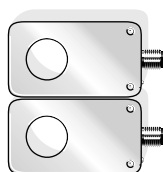

No mutual interference for parallel mounting of two sensors.

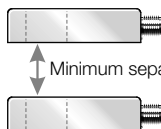

When stacking multiple sensors, the separation must be at least 50 mm.

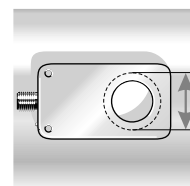

The opening should be at least $\varnothing 35$ mm for flat installation on metal surfaces.